

# WAFER ROBOT S Series



HIWIN Support



About HIWIN

# Product Series

- Single Arm

Applicable for 2~12 inch foundry



- Dual Arm

Applicable for 2~12 inch foundry



## Key Components

The key components in the robot arm, including ballscrew and direct drive motor, are all developed and manufactured by HIWIN. The parts are directly connected, and the software and hardware are vertically integrated to provide a high-quality robotic arm to enhance your efficiency and competitiveness. Customized services can be provided as per customer's requirements.

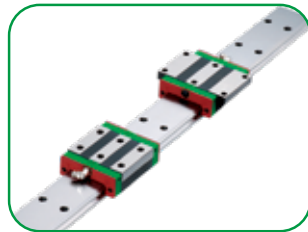

## Semiconductor Industry

- Wafer Handling

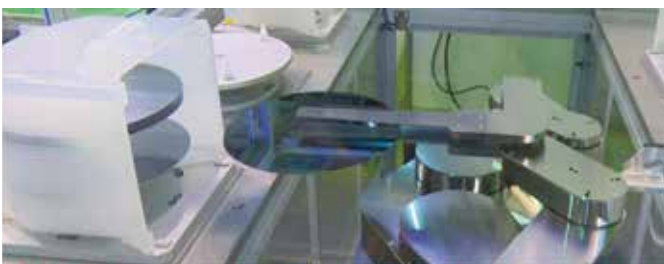

- Wafer Flipping



## LED Industry

- Sapphire Handling



- Ring Gripping



## TFT-LCD (Small Panel)

- Panel Handling



- Storage Application



# Specifications

Model		Single Arm- RWS/RWSS Series	Dual Arm- RWD/RWDS Series
		135 mm / 185 mm	
Rated Load		0.5kg/2kg (Note)	
R/W Axis	Velocity	750 mm/sec	
T Axis	Range	0~340 deg	
	Angular Velocity	250 deg/sec	
Z Axis	Stroke	340/400/500 mm	
Velocity		250 mm/sec	
Mounting Method		Bottom / Top Lock	
Weight		45-55 kg (w/o controller)	
Cleanliness		Class 100	
Repeatability		±0.1 mm	
Control Interface		RS232 / Ethernet	
I/O		14 IN / 9 OUT	
Wire Length		5 m	
Voltage		200~240 V (AC) (Single Phase)	
Current		5 A	
Vacuum		φ 6 ; -40~-60kPa	

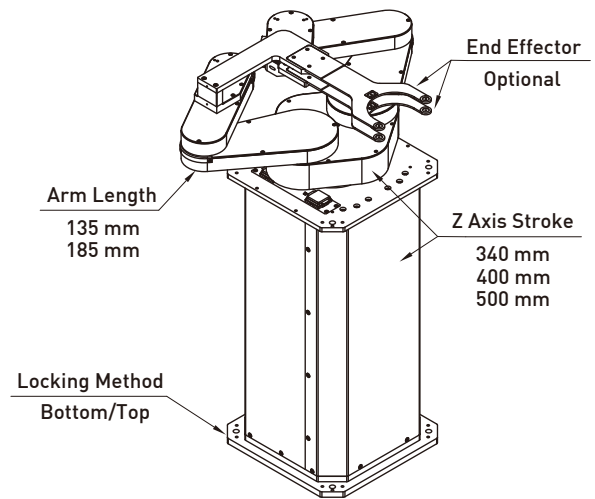

Note: Rated load 2kg is for RWSS, RWDS Series only.

# Table

RW	-	S	-	T	Z400	R135	-	Cta	-	F	-	M	-	T
Wafer Robot		Model		Mounting	Z Axis	Reach		End Effector		Fork		Mapping Sensor		Teach Pendant
RW		S: Single D: Dual SS: Single arm heavy load DS: Dual arm heavy load		T: Top B: Bottom	Z340 Z400 Z500 Z*: Customized	R135 R185 03R185 (Heavy load specifi- cation) *: Customized		Ata: Vacuum Cta: Grip Rta: Flip		F: Fork No Mark: None		M : LV-H47 (Reflection) M(M-DW1) : M-DW1 (Reflection) M(EX-43QS) : EX-43QS (Reflection) M(FU-18M) : FU-18M (Contrast) No Mark: None		T:Standard T2:S2 No Mark: None

## Optional

- Fork (Various types are available for customer's different applications.)

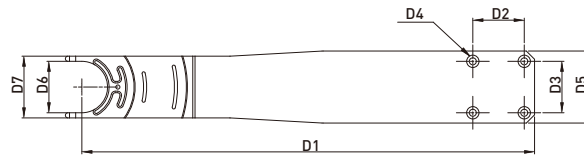

Figure	Code	Suitable for Wafer Size	Type	D1	D2	D3	D4	D5	D6	D7	t (End Thickness)
	F02	8"~12"	Vacuum Suction	250	40	35	M3	60	100	140	3.5
	F04	2"~6"	Vacuum Suction	186	25	25	M3	35	N/A	20	2
	F08	6", 8"	Vacuum Suction	195	25	25	M3	35	55	85	2.4
	F21	8", 12"	Vacuum Suction	250	40	35	M3	60	115	150	3
	F31	4", 6"	Vacuum Suction	208	25	25	M3	35	56	70	2
	F34	12"	Edge Gripping	232	35	35	M3	50	N/A	70	5
	F148	8"	Edge Gripping	182	35	35	M3	50	N/A	70	3

- Mapping Sensor



The RW series supports the mapping function. The optional Mapping Sensor allows the arm to detect whether the wafers or substrates inside the cassette are overlapped or slanted before starting the pick and place.

- Teach Pendant



- Compact sized, easy to carry and operate, users can do function instructing and testing for pick and place application.
- Graphical function keys for better understanding and easy operation.
- Safety switch in place to prevent the user from accidentally touching the function key.

- End Effector



Vacuum Suction Type

Clamp Type

Flip Type

- Vacuum Suction Type: Handling the wafer or substrate by vacuum suction.
- Clamp Type: Clamp the wafer at the edge of the wafer for handling.
- Flip Type: The wafers or substrates are transferred by vacuum suction, and can be flipped according to user requirements.

## RWS-T / RWSS-T

340°[Mapping Rotational Range]

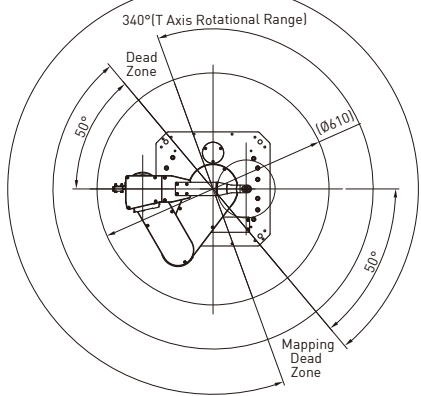

Rotational Range Detail

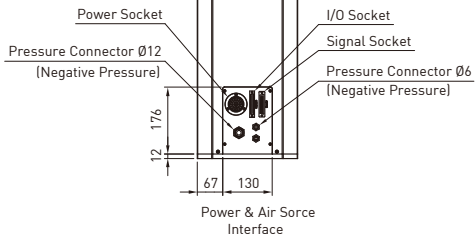
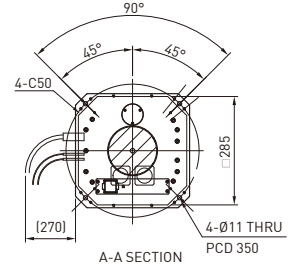
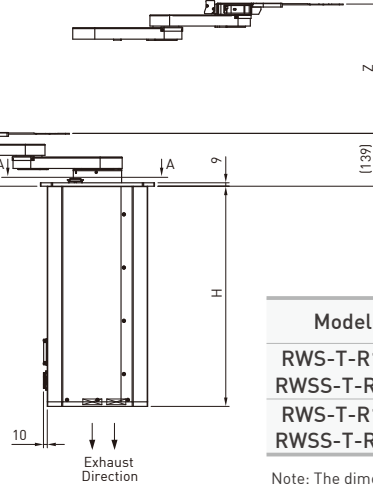
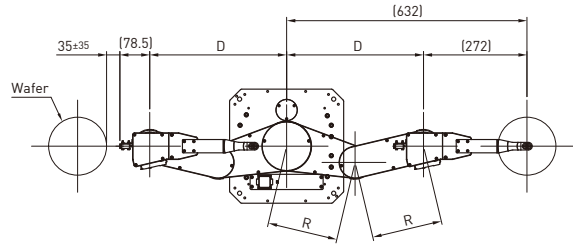

Power & Air Source Interface

Model	R	D	H	Z
RWS-T-R135	135	260	580/640/730	340/400/500
RWSS-T-R135	135	260	580/640/730	340/400/500
RWS-T-R185	185	360	580/640/730	340/400/500
RWSS-T-R185	185	360	580/640/730	340/400/500

Note: The dimensions on drawing will differ as per different end-effector model selected, for detailed dimensions, please contact HIWIN.

## RWS-B / RWSS-B

340°[Mapping Rotational Range]

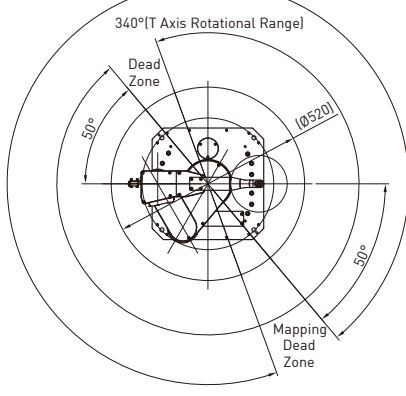

Rotational Range Detail

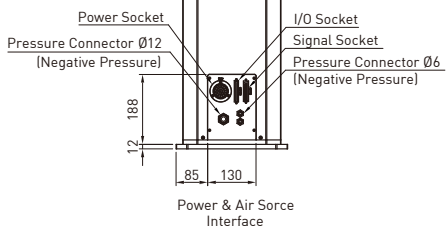
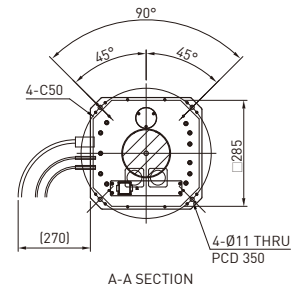
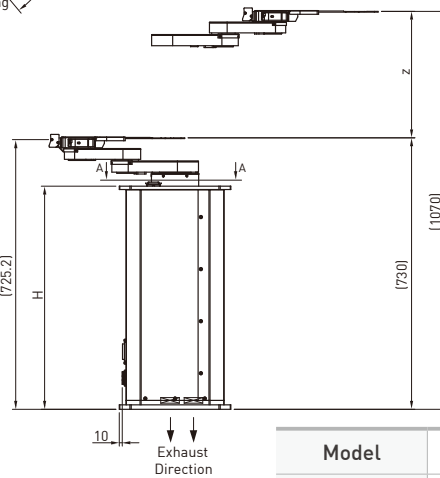
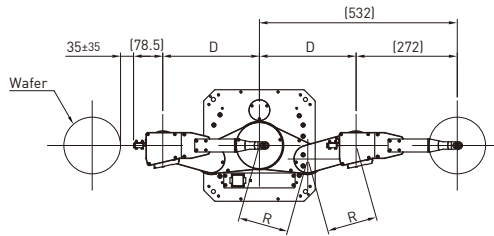

Power & Air Source Interface

Model	R	D	H	Z
RWS-B-R135	135	260	592/652/742	340/400/500
RWSS-B-R135	135	260	592/652/742	340/400/500
RWS-B-R185	185	360	592/652/742	340/400/500
RWSS-B-R185	185	360	592/652/742	340/400/500

Note: The dimensions on drawing will differ as per different end-effector model selected, for detailed dimensions, please contact HIWIN.

## RWD-T / RWDS-T

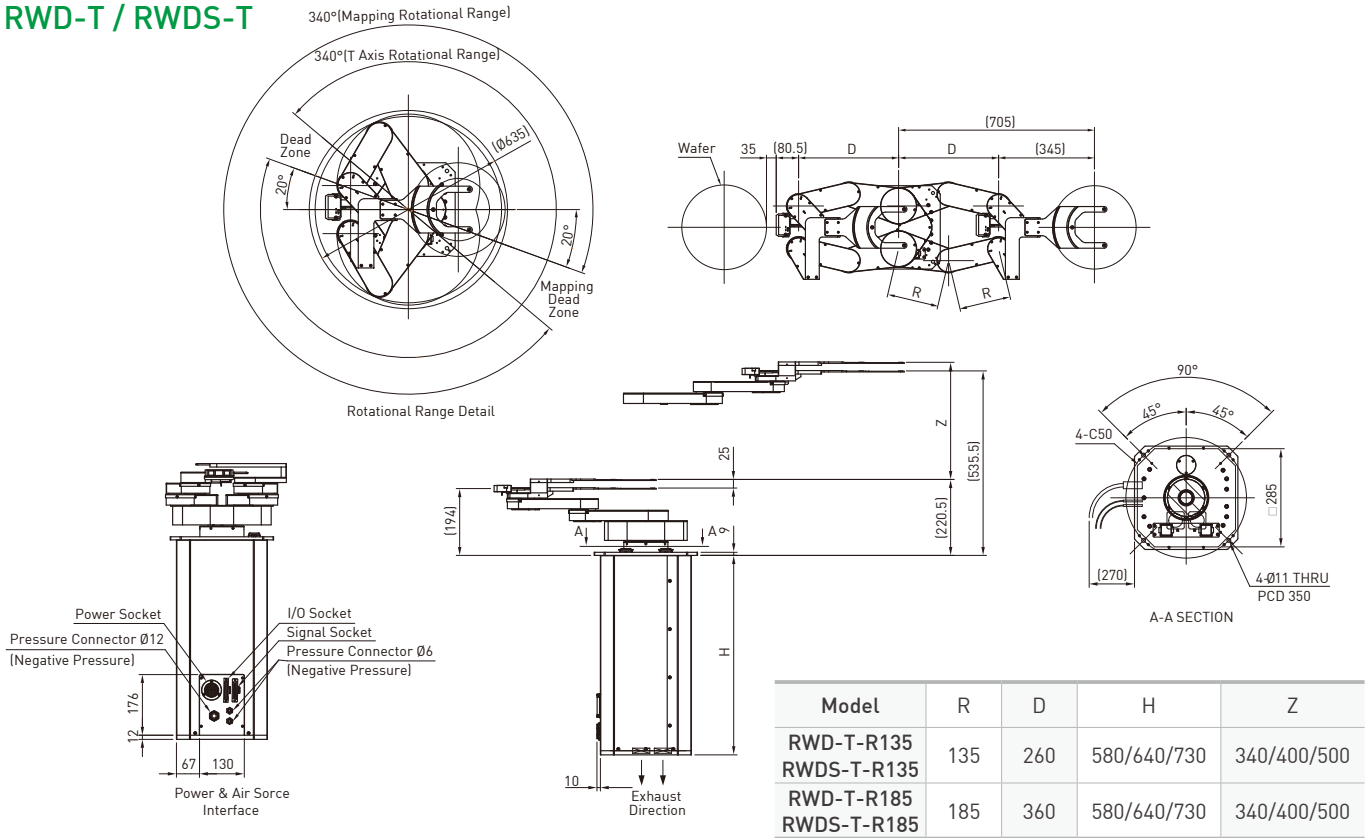

Note: The dimensions on drawing will differ as per different end-effector model selected, for detailed dimensions, please contact HIWIN.

## RWD-B / RWDS-B

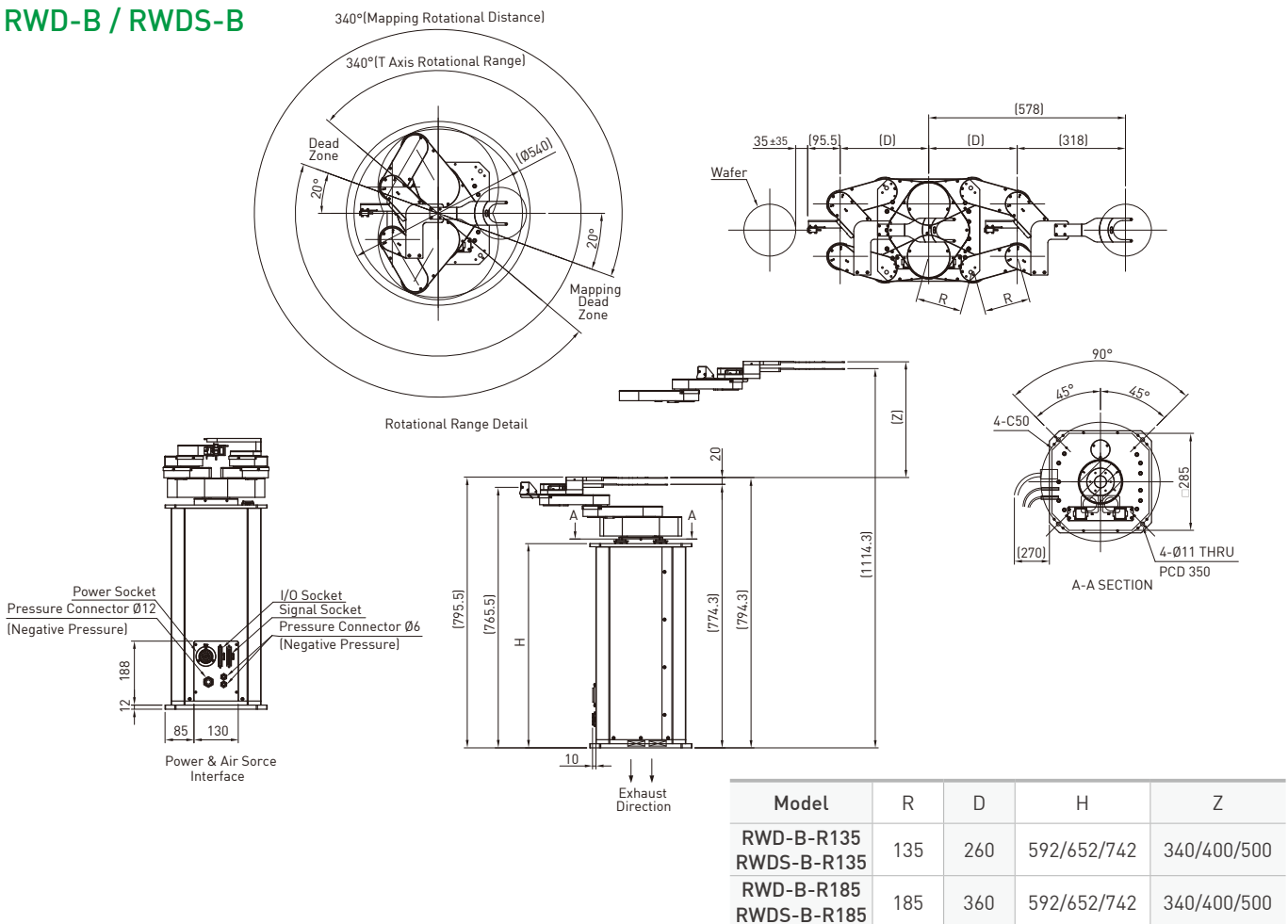

Note: The dimensions on drawing will differ as per different end-effector model selected, for detailed dimensions, please contact HIWIN.

# Wafer Robot Inquiry Form

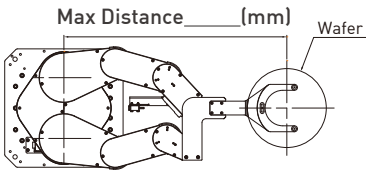
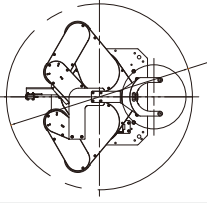
Company Name :		Date :			
Contact :		Visitor :			
Tel :					
Address :					
Conditions	Dimension and Specification	<input type="checkbox"/> Circle : _____ (inch) <input type="checkbox"/> Square : _____ x _____ (mm) <input type="checkbox"/> Other : _____		Thickness : _____ ~ _____ (μm)	
		Weight : _____ kg	Material : _____	<input type="checkbox"/> Untouchable Area of Wafer: _____	
		Cassette Pitch: <input type="checkbox"/> Standard <input type="checkbox"/> Customize(mm) (Standard: 2~6 inches : 4.76mm, 8 inches : 6.35mm, 12 inches : 10mm)		Application: <input type="checkbox"/> SEMI <input type="checkbox"/> LED <input type="checkbox"/> Other	
				Manufacturing Process: _____	
Robot Body	Z Axis Stroke	<input type="checkbox"/> 340mm <input type="checkbox"/> 400mm <input type="checkbox"/> 500mm			
	Mounting Type	<input type="checkbox"/> Top : <input type="checkbox"/> Bottom (Integrate with External Axis)			
Robot Arm	Type of Arm	Type : <input type="checkbox"/> Single : <input type="checkbox"/> Dual	Arm Length : <input type="checkbox"/> R135 <input type="checkbox"/> R185 (Please refer the pick and place distance as below.) (R135 without Fork: 410mm, R185 without Fork: 510mm)		
	Working Distance			 Min Rotational Distance ≤ ∅ _____ (mm)	
End Effector Type		<input type="checkbox"/> Vacuum <input type="checkbox"/> Gripping <input type="checkbox"/> Flipping			
Communication		<input type="checkbox"/> Ethernet(TCP/IP) <input type="checkbox"/> RS-232 <input type="checkbox"/> I/O (HIWIN I/O Interpreter Module)			
Environment	Cleanroom	<input type="checkbox"/> None : <input type="checkbox"/> Class100 : <input type="checkbox"/> Class _____			
	Temperature	<input type="checkbox"/> 10°C~40°C : <input type="checkbox"/> Other _____ °C			
	Pressure	<input type="checkbox"/> Atmosphere : <input type="checkbox"/> Other _____ kPa			
Other	Fork	<input type="checkbox"/> None : <input type="checkbox"/> Need : <input type="checkbox"/> Other _____	Material : _____	<input type="checkbox"/> Antistatic : ≤ _____ (ohm)	
	MAP Sensor	<input type="checkbox"/> None : <input type="checkbox"/> Need : <input type="checkbox"/> Other (Brand: _____; Model: _____)			
	Teach Pendant	<input type="checkbox"/> None : <input type="checkbox"/> Need			
	Track Axis	<input type="checkbox"/> None : <input type="checkbox"/> Need , Stroke _____ mm (Only with HIWIN Products)			
Experience of Using Robot		Brand: _____; Model: _____			

Other function/Requirement description :

(The information below is suggested by HIWIN engineer.)

Recommended Specification :

(HIWIN) Written by :

NOTE:

# HRC-W Controller

## Communication Control



Content	Specification
Dimension	527mm x 252mm x 202mm(Standard) 390mm x 380mm x 275mm(S2)
Weight	16.5 kg
Power Input	Single Phase AC200~240V/5A
Maximum Power Usage	1200W
Communication	RS232 / Ethernet (Select one)
I/O	14 IN / 9 OUT

- Can use the teach pendant to guide the arm position of robot.
- Host Controller can be communicated through RS232/Ethernet protocol by macro command to control Robot movement.

## Simple Macro Command Procedure

- Built-in status, parameters, and motion commands (including security protection systems) help users do process plannings more flexibly.

Note: The contents of this example and the command list are taken from the list of the macro command in the HRC-W Electrical Control Box User Manual. For details, please download it from the HIWIN website or contact HIWIN.



## High Precision Control

- HIWIN's own high-precision, high rigidity direct drive motor.

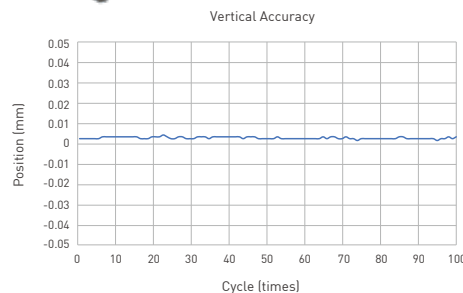

## Global Sales And Customer Service Site

**HIWIN GmbH**  
OFFENBURG, GERMANY  
www.hiwin.de  
www.hiwin.eu  
info@hiwin.de

**HIWIN USA**  
CHICAGO, U.S.A.  
www.hiwin.com  
info@hiwin.com

**HIWIN JAPAN**  
KOBE · TOKYO · NAGOYA · NAGANO · TOHOKU · SHIZUOKA ·  
HOKURIKU · HIROSHIMA · FUKUOKA · KUMAMOTO, JAPAN  
www.hiwin.co.jp  
info@hiwin.co.jp

**HIWIN Srl**  
BRUGHERIO, ITALY  
www.hiwin.it  
info@hiwin.it

**HIWIN Schweiz GmbH**  
JONA, SWITZERLAND  
www.hiwin.ch  
info@hiwin.ch

**HIWIN s.r.o.**  
BRNO, CZECH REPUBLIC  
www.hiwin.cz  
info@hiwin.cz

**HIWIN FRANCE**  
STRASBOURG, FRANCE  
www.hiwin.fr  
info@hiwin.de

**HIWIN SINGAPORE**  
SINGAPORE  
www.hiwin.sg  
info@hiwin.sg

**HIWIN KOREA**  
SUWON · CHANGWON, KOREA  
www.hiwin.kr  
info@hiwin.kr

**HIWIN CHINA**  
SUZHOU, CHINA  
www.hiwin.cn  
info@hiwin.cn

**HIWIN BULGARIA**  
SOFIA, BULGARIEN  
www.hiwin.bg  
info@hiwin.bg

# HIWIN®

**HIWIN TECHNOLOGIES CORP.**

No. 7, Jingke Road,  
Taichung Precision Machinery Park,  
Taichung 408208, Taiwan  
Tel: +886-4-23594510  
Fax: +886-4-23594420  
www.hiwin.tw  
www.hiwin.support.com  
business@hiwin.tw (Sales)  
robotservice@hiwin.tw (Customer Service)

- HIWIN is a registered trademark of HIWIN Technologies Corp. For your protection, avoid buying counterfeit products from unknown sources.
- Actual products may differ from specifications and photos provided in this catalog. These differences may be the result of various factors including product improvements.
- HIWIN website for patented product directory: [http://www.hiwin.tw/Products/Products\\_patents.aspx](http://www.hiwin.tw/Products/Products_patents.aspx)
- HIWIN will not sell or export products or processes restricted under the "Foreign Trade Act" or related regulations. Export of restricted products should be approved by proper authorities in accordance with relevant laws and shall not be used to manufacture or develop nuclear, biochemical, missiles or other weapons.

The specifications in this catalog are subject to change without notification.

Copyright © HIWIN Technologies Corp.

©2020 FORM C03DE02-2010 (PRINTED IN TAIWAN)